

## Y2 SERIES THREE PHASE INDUCTION MOTOR



FRAME: 63~355

POWER: 0.12~315KW

DUTY: S1

INSULATION: F

### Applications:

General purpose including cutting machines, pumps, fans, conveyors, machines tools of farm duty and food process .

### Features :

High efficiency and energy saving ,low noise and little vibration.  
Insulation class :F ; Protection class :IP54 or IP55

### Circumstance for use :

The altitude not exceeding 1000m above sea level .The ambient temperature subject to seasonal variations but not exceeding +40°C and not less than -15°C.

## PERFORMANCE DATA

380V 50Hz

Type	KW	Current A	r/min	Eff %	Power factor	Locked rotor torque Rated torque	Locked rotor current Rated current	Breakdown torque Rated torque
Synchronous speed 3000r/min								
Y2-63M1-2	0.18	0.53	2720	65.0	0.80	2.2	5.5	2.2
Y2-63M2-2	0.25	0.69	2720	68.0	0.81	2.2	5.5	2.2
Y2-71M1-2	0.37	0.99	2740	70.0	0.81	2.2	6.1	2.2
Y2-71M2-2	0.55	1.4	2740	73.0	0.82	2.2	6.1	2.3
Y2-80M1-2	0.75	1.8	2840	75.0	0.83	2.2	6.1	2.3
Y2-80M2-2	1.1	2.6	2840	77.0	0.84	2.2	7.0	2.3
Y2-90S-2	1.5	3.4	2845	79.0	0.84	2.2	7.0	2.3
Y2-90L-2	2.2	4.9	2845	81.0	0.85	2.2	7.0	2.3
Y2-100L-2	3	6.3	2860	83.0	0.87	2.2	7.5	2.3
Y2-112M-2	4	8.1	2880	85.0	0.88	2.2	7.5	2.3
Y2-132S1-2	5.5	11.0	2900	86.0	0.88	2.2	7.5	2.3
Y2-132S2-2	7.5	14.9	2900	87.0	0.88	2.2	7.5	2.3
Y2-160M1-2	11	21.3	2930	88.0	0.89	2.2	7.5	2.3
Y2-160M2-2	15	28.8	2930	89.0	0.89	2.2	7.5	2.3
Y2-160L-2	18.5	34.7	2930	90.0	0.90	2.2	7.5	2.3
Y2-180M-2	22	41.0	2940	90.0	0.90	2.0	7.5	2.3
Y2-200L1-2	30	55.5	2950	91.2	0.90	2.0	7.5	2.3
Y2-200L2-2	37	67.9	2950	92.0	0.90	2.0	7.5	2.3
Y2-225M-2	45	82.3	2960	92.3	0.90	2.0	7.5	2.3

## PERFORMANCE DATA

**380V 50Hz**

Type	KW	Current A	r/min	Eff %	Power factor	Locked rotor torque Rated torque	Locked rotor current Rated current	Breakdown torque Rated torque
Synchronous speed 3000r/min								
Y2-250M-2	55	100	2965	92.5	0.90	2.0	7.5	2.3
Y2-280S-2	75	135	2970	93.0	0.90	2.0	7.5	2.3
Y2-280M-2	90	160	2970	93.8	0.91	2.0	7.5	2.3
Y2-315S-2	110	195	2975	94.0	0.91	1.8	7.1	2.2
Y2-315M-2	132	233	2975	94.5	0.91	1.8	7.1	2.2
Y2-315L1-2	160	279	2975	94.6	0.92	1.8	7.1	2.2
Y2-315L2-2	200	348	2975	94.8	0.92	1.8	7.1	2.2
Y2-355M-2	250	433	2980	95.3	0.92	1.6	7.1	2.2
Y2-355L-2	315	544	2980	95.6	0.92	1.6	7.1	2.2
Synchronous speed 1500r/min								
Y2-63M1-4	0.12	0.44	1310	57.0	0.72	2.1	4.4	2.2
Y2-63M2-4	0.18	0.62	1310	60.0	0.73	2.1	4.4	2.2
Y2-71M1-4	0.25	0.79	1330	65.0	0.74	2.1	5.2	2.2
Y2-71M2-4	0.37	1.12	1330	67.0	0.75	2.1	5.2	2.2
Y2-80M1-4	0.55	1.6	1390	71.0	0.75	2.4	5.2	2.3
Y2-80M2-4	0.75	2.0	1390	73.0	0.76	2.3	6.0	2.3
Y2-90S-4	1.1	2.9	1390	75.0	0.77	2.3	6.0	2.3
Y2-90L-4	1.5	3.7	1390	78.0	0.79	2.3	6.0	2.3
Y2-100L1-4	2.2	5.2	1410	80.0	0.81	2.3	7.0	2.3
Y2-100L2-4	3	6.8	1410	82.0	0.82	2.3	7.0	2.3
Y2-112M-4	4	8.8	1440	84.0	0.82	2.3	7.0	2.3
Y2-132S-4	5.5	11.8	1440	85.0	0.83	2.3	7.0	2.3
Y2-132M-4	7.5	15.6	1440	87.0	0.84	2.3	7.0	2.3
Y2-160M-4	11	22.3	1460	88.0	0.84	2.2	7.0	2.3
Y2-160L-4	15	30.1	1460	89.0	0.85	2.2	7.5	2.3
Y2-180M-4	18.5	36.1	1470	90.5	0.86	2.2	7.5	2.3
Y2-180L-4	22	42.7	1470	91.0	0.86	2.2	7.5	2.3
Y2-200L-4	30	57.6	1470	92.0	0.86	2.2	7.2	2.3
Y2-225S-4	37	69.9	1475	92.5	0.87	2.2	7.2	2.3
Y2-225M-4	45	84.7	1475	92.8	0.87	2.2	7.2	2.3
Y2-250M-4	55	103	1480	93.0	0.87	2.2	7.2	2.3
Y2-280S-4	75	140	1480	93.8	0.87	2.2	7.2	2.3
Y2-280M-4	90	167	1480	94.2	0.87	2.2	7.2	2.3
Y2-315S-4	110	201	1480	94.5	0.88	2.1	6.9	2.2
Y2-315M-4	132	240	1480	94.8	0.88	2.1	6.9	2.2
Y2-315L1-4	160	288	1480	94.9	0.89	2.1	6.9	2.2
Y2-315L2-4	200	359	1480	95.0	0.89	2.1	6.9	2.2
Y2-355M-4	250	443	1490	95.3	0.90	2.1	6.9	2.2
Y2-355L-4	315	556	1490	95.6	0.90	2.1	6.9	2.2
Synchronous speed 1000r/min								
Y2-71M1-6	0.18	0.74	850	56.0	0.66	1.9	4.0	2.0
Y2-71M2-6	0.25	0.95	850	59.0	0.68	1.9	4.0	2.0
Y2-80M1-6	0.37	1.3	885	62.0	0.70	1.9	4.7	2.0

## PERFORMANCE DATA

380V 50Hz

Type	KW	Current A	r/min	Eff %	Power factor	Locked rotor torque Rated torque	Locked rotor current Rated current	Breakdown torque Rated torque
Synchronous speed 1000r/min								
Y2-80M2-6	0.55	1.8	885	65.0	0.72	1.9	4.7	2.1
Y2-90S-6	0.75	2.3	910	69.0	0.72	2.0	5.5	2.1
Y2-90L-6	1.1	3.2	910	72.0	0.73	2.0	5.5	2.1
Y2-100L-6	1.5	3.9	920	76.0	0.75	2.0	5.5	2.1
Y2-112M-6	2.2	5.6	935	79.0	0.76	2.0	6.5	2.1
Y2-132S-6	3	7.4	960	81.0	0.76	2.1	6.5	2.1
Y2-132M1-6	4	9.8	960	82.0	0.76	2.1	6.5	2.1
Y2-132M2-6	5.5	12.9	965	84.0	0.77	2.1	6.5	2.1
Y2-160M-6	7.5	17.2	970	86.0	0.77	2.0	6.5	2.1
Y2-160L-6	11	24.2	970	87.5	0.78	2.0	6.5	2.1
Y2-180M-6	15	31.6	970	89.0	0.81	2.0	7.0	2.1
Y2-200L1-6	18.5	38.6	980	90.0	0.81	2.1	7.0	2.1
Y2-200L2-6	22	44.7	980	90.0	0.83	2.1	7.0	2.1
Y2-225M-6	30	59.3	980	91.5	0.84	2.0	7.0	2.1
Y2-250M-6	37	71.1	980	92.0	0.86	2.1	7.0	2.1
Y2-280S-6	45	85.9	980	92.5	0.86	2.1	7.0	2.0
Y2-280M-6	55	105	980	92.8	0.86	2.1	7.0	2.0
Y2-315S-6	75	142	985	93.5	0.86	2.0	7.0	2.0
Y2-315M-6	90	170	985	92.8	0.86	2.0	7.0	2.0
Y2-315L1-6	110	207	985	94.0	0.86	2.0	6.7	2.0
Y2-315L2-6	132	245	985	94.2	0.87	2.0	6.7	2.0
Y2-355M1-6	160	292	990	94.5	0.88	1.9	6.7	2.0
Y2-355M2-6	200	365	990	94.7	0.88	1.9	6.7	2.0
Y2-355L-6	250	455	990	94.9	0.88	1.9	6.7	2.0
Synchronous speed 750r/min								
Y2-80M1-8	0.18	0.88	645	51.0	0.61	1.8	3.3	1.9
Y2-80M2-8	0.25	1.15	645	54.0	0.61	1.8	3.3	1.9
Y2-90S-8	0.37	1.49	670	62.0	0.61	1.8	4.0	1.9
Y2-90L-8	0.55	2.17	670	63.0	0.61	1.8	4.0	2.0
Y2-100L1-8	0.75	2.4	680	71.0	0.67	1.8	4.0	2.0
Y2-100L2-8	1.1	3.4	680	73.0	0.69	1.8	5.0	2.0
Y2-112M-8	1.5	4.4	690	75.0	0.69	1.8	5.0	2.0
Y2-132S-8	2.2	6	705	78.0	0.71	1.8	6.0	2.0
Y2-132M-8	3	7.9	705	79.0	0.73	1.8	6.0	2.0
Y2-160M1-8	4	10.3	720	81.0	0.73	1.9	6.0	2.0
Y2-160M2-8	5.5	13.6	720	83.0	0.74	2.0	6.0	2.0
Y2-160L-8	7.5	17.8	720	85.5	0.75	2.0	6.0	2.0
Y2-180L-8	11	25.1	730	87.5	0.76	2.0	6.6	2.0
Y2-200L-8	15	34.1	730	88.0	0.76	2.0	6.6	2.0
Y2-225S-8	18.5	41.4	730	90.0	0.76	1.9	6.6	2.0
Y2-225M-8	22	47.4	730	90.5	0.78	1.9	6.6	2.0
Y2-250M-8	30	63.4	730	91.0	0.79	1.9	6.6	2.0
Y2-280S-8	37	77.8	740	91.5	0.79	1.9	6.6	2.0

## PERFORMANCE DATA

380V 50Hz

Type	KW	Current A	r/min	Eff %	Power factor	Locked rotor torque Rated torque	Locked rotor current Rated current	Breakdown torque Rated torque
Synchronous speed 750r/min								
Y2-280M-8	45	94.1	735	92.0	0.79	1.9	6.6	2.0
Y2-315S-8	55	111	735	92.8	0.81	1.8	6.6	2.0
Y2-315M-8	75	151	735	93.0	0.81	1.8	6.6	2.0
Y2-315L1-8	90	178	735	93.8	0.82	1.8	6.6	2.0
Y2-315L2-8	110	217	735	94.0	0.82	1.8	6.4	2.0
Y2-355M1-8	132	261	740	93.7	0.82	1.8	6.4	2.0
Y2-355M2-8	160	315	740	94.2	0.82	1.8	6.4	2.0
Y2-355L-8	200	387	740	94.5	0.83	1.8	6.4	2.0
Synchronous speed 600r/min								
Y2-315S-10	45	99.6	590	91.5	0.75	1.5	6.2	2.0
Y2-315M-10	55	121	590	92.0	0.75	1.5	6.2	2.0
Y2-315L1-10	75	162	590	92.5	0.76	1.5	6.2	2.0
Y2-315L2-10	90	191	590	93.0	0.77	1.5	6.2	2.0
Y2-355M1-10	110	230	590	93.2	0.78	1.3	6.0	2.0
Y2-355M2-10	132	275	590	93.5	0.78	1.3	6.0	2.0
Y2-355L-10	160	333	590	93.5	0.78	1.3	6.0	2.0

## DIMENSIONS(mm)

B14

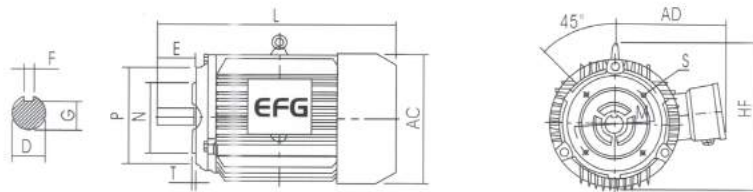

B34

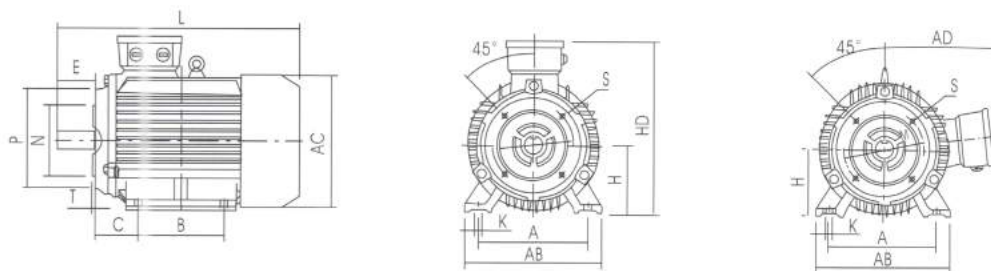

Frame	Pole	Mounting Dimension															Overall Dimension						
		A	B	C	D	E	F	G	H	M	N	P	R	S	T	K	Flange hole number	AB	AC	AD	HD	HF	L
63M	2.4	110	80	40	11	23	4	8.5	63	75	60	90	0	M5	2.5	7	4	135	130	70	180	130	230
71M	2.4.6	112	90	45	14	30	5	11	71	85	70	105	0	M6	2.5	7	4	150	145	80	195	145	255
80M	2.4.6.8	125	100	50	19	40	6	15.5	80	100	80	120	0	M6	3	10	4	165	175	145	214	185	295
90S	2.4.6.8	140	100	56	24	50	8	20	90	115	95	140	0	M8	3	10	4	180	195	155	250	195	320
90L	2.4.6.8	140	125	56	24	50	8	20	90	115	95	140	0	M8	3	10	4	180	195	155	250	195	345
100L	2.4.6.8	160	140	63	28	60	8	24	100	130	110	160	0	M8	3.5	12	4	205	215	180	270	245	385
112M	2.4.6.8	190	140	70	28	60	8	24	112	130	110	160	0	M8	3.5	12	4	230	240	190	300	265	400

## DIMENSIONS(mm)

**B3**

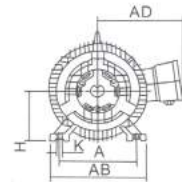
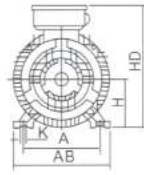
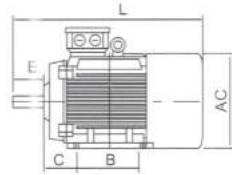
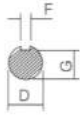

**B5**

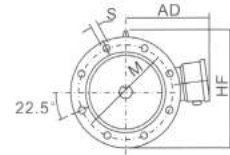
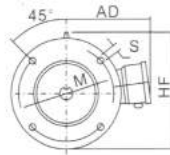
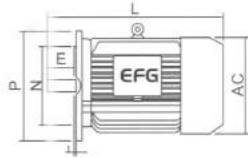

**B35**

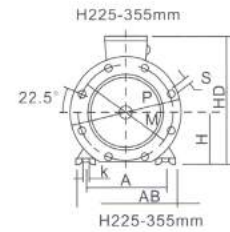
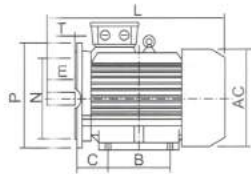

Frame	Pole	Mounting Dimension											Overall Dimension									
		A	B	C	D	E	F	G	H	M	N	P	R	S	T	K	AB	AC	AD	HD	HF	L
63M	2.4	100	80	40	11	23	4	8.5	63	115	95	140	0	10	3	7	135	130	70	180	130	230
71M	2.4.6	112	90	45	14	30	5	11	71	130	110	160	0	10	3.5	7	150	145	80	195	145	255
80M	2.4.6.8	125	100	50	19	40	6	15.5	80	165	130	200	0	12	3.5	10	165	175	145	220	185	295
90S	2.4.6.8	140	100	56	24	50	8	20	90	165	130	200	0	12	3.5	10	180	195	155	250	195	320
90L	2.4.6.8	140	125	56	24	50	8	20	90	165	130	200	0	12	3.5	10	180	195	155	250	195	345
100L	2.4.6.8	160	140	63	28	60	8	24	100	215	180	250	0	15	4	12	205	215	180	270	245	385
112M	2.4.6.8	190	140	70	28	60	8	24	112	215	180	250	0	15	4	12	230	240	190	300	265	400
132S	2.4.6.8	216	140	89	38	80	10	33	132	265	230	300	0	15	4	12	270	275	210	345	315	470
132M	2.4.6.8	216	178	89	38	80	10	33	132	265	230	300	0	15	4	12	270	275	210	345	315	510
160M	2.4.6.8	254	210	108	42	110	12	37	160	300	250	350	0	19	5	15	320	330	255	420	385	615
160L	2.4.6.8	254	254	108	42	110	12	37	160	300	250	350	0	19	5	15	320	330	255	420	385	670
180M	2.4.6.8	279	241	121	48	110	14	42.5	180	300	250	350	0	19	5	15	355	380	280	455	430	700
180L	2.4.6.8	279	279	121	48	110	14	42.5	180	300	250	350	0	19	5	15	355	380	280	455	430	740
200L	2.4.6.8	318	305	133	55	110	16	49	200	350	300	400	0	19	5	19	395	420	305	505	480	770
225S	4.8	356	286	149	60	140	18	53	225	400	350	450	0	19	5	19	435	470	335	560	535	815
225M	2	356	311	149	55	110	16	49	225	400	350	450	0	19	5	19	435	470	335	560	535	820
	4.6.8				60	140	18	53														845
250M	2	406	349	168	60	140	18	53	250	500	450	550	0	19	5	24	490	510	370	615	595	910
	4.6.8				65	140	18	58														
280S	2	457	368	190	65	140	18	58	280	500	450	550	0	19	5	24	550	580	410	680	650	985
	4.6.8				75	140	20	67.5														
280M	2	457	419	190	65	140	18	58	280	500	450	550	0	24	5	19	550	580	410	680	650	1035
	4.6.8.10				75	140	20	67.5														
315S	2	508	406	216	65	140	18	58	315	600	550	660	0	24	6	28	635	645	530	845	—	1160
	4.6.8.10				80	170	22	71													—	1270
315M	2	508	457	216	65	140	18	58	315	600	550	660	0	24	6	28	635	645	530	845	—	1190
	4.6.8.10				80	170	22	71													—	1300
315L	2	508	508	216	65	140	18	58	315	600	550	660	0	24	6	28	635	645	530	845	—	1190
	4.6.8.10				80	170	22	71													—	1300
355M	2	610	560	254	75	140	20	67.5	355	740	680	800	0	24	6	28	730	710	655	1010	—	1500
	4.6.8.10				95	170	25	86													—	1530
355L	2	610	630	254	75	140	20	67.5	355	740	680	800	0	24	6	28	730	710	655	1010	—	1500
	4.6.8.10				95	170	25	86													—	1530

## DIMENSIONS(mm)

V1

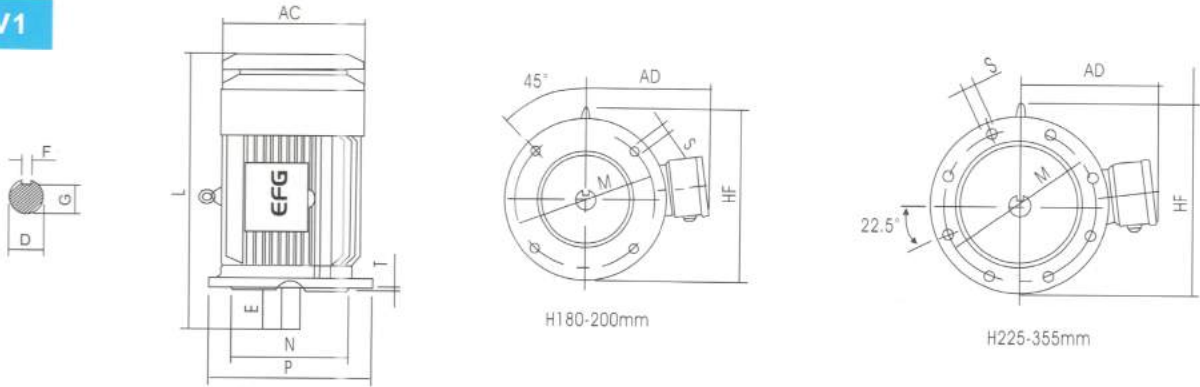

Frame	Pole	Mounting Dimension											Overall Dimension			
		D	E	F	G	M	N	P	R	S	T	Flange hole number	AC	AD	HF	L
180M	2.4.6.8	48	110	14	42.5	300	250	350	0	19	5	4	380	280	500	760
180L	2.4.6.8	48	110	14	42.5	300	250	350	0	19	5	4	380	280	500	800
200L	2.4.6.8	55	110	16	49	350	300	400	0	19	5	4	420	305	550	840
225S	4.8	60	140	18	53	400	350	450	0	19	5	8	470	335	610	905
225M	2	55	110	16	49	400	350	450	0	19	5	8	470	335	610	910
	4.6.8	60	140	18	53											
250M	2	60	140	18	53	500	450	550	0	19	5	8	510	370	650	1015
	4.6.8	65	140	18	58											
280S	2	65	140	18	58	500	450	550	0	19	5	8	580	410	720	1110
	4.6.8	75	140	20	67.5											
280M	2	65	140	18	58	500	450	550	0	19	5	8	580	410	720	1150
	4.6.8	75	140	20	67.5											
315S	2	65	140	18	58	600	550	660	0	24	6	8	645	530	900	1280
	4.6.8.10	80	170	22	71											1510
315M	2	65	140	18	58	600	550	660	0	24	6	8	645	530	900	1310
	4.6.8.10	80	170	22	71											1430
315L	2	65	140	18	58	600	550	660	0	24	6	8	645	530	900	1310
	4.6.8.10	80	170	22	71											1430
355M	2	75	140	20	67.5	740	680	800	0	24	6	8	710	655	1010	1640
	4.6.8.10	95	170	25	86											1670
355L	2	75	140	20	67.5	740	680	800	0	24	6	8	710	655	1010	1640
	4.6.8.10	95	170	25	86											1670

\*DATA SUBJECT TO CHANGE WITHOUT NOTICE

## MOUNTING ARRANGEMENTS OF THE MOTORS

Conventional mounting type and suitable frame size are given in following table(with "√")

Frame	Basic Type			Derived Type											
	B3	B5	B35	V1	V3	V5	V6	B6	B7	B8	V15	V36	B14	B34	V18
63~112	√	√	√	√	√	√	√	√	√	√	√	√	√	√	√
132~160	√	√	√	√	√	√	√	√	√	√	√	√	—	—	—
180~280	√	√	√	√	—	—	—	—	—	—	—	—	—	—	—
315~355	√	—	√	√	—	—	—	—	—	—	—	—	—	—	—

